

User Manual

**Electromechanical Locking Device
HD-Lock Modbus Ex-Proof
Ord. No. 102100.1**

Ex II 2G Ex db IIB T4 Gb

Series (Modbus)



Content

1	General	3
1.1	Characteristics of the locking device.....	3
1.2	Scope of delivery	3
2	Installation.....	4
2.1	General installation.....	4
2.2	Door Stroke direction.....	7
2.3	Switching Point (Door-Closed/Open_).....	8
3	Electrical interface.....	9
4	Commissioning.....	10
5	Troubleshooting	10
6	Modbus Protocol	11
7	Technical data.....	12
8	Figures.....	12
9	Notes.....	13

Disclaimer of Liability

© Copyright BSS Baumann Sicherheitssysteme GmbH 2021
All rights reserved.

Disclosure and copying of this User Manual is prohibited if not authorised. Violation obligates compensation for damages. All rights reserved.

Every precaution has been taken to ensure that the information concerning hardware and software explained in this document is accurate and correct. However, deviations may occur so that no guarantee can be made for complete agreement with the documentation. However, the information in this publication is reviewed regularly and any necessary corrections are included in subsequent editions. We appreciate your feedback concerning improvement of this user manual. Subject to technical modifications.

User Manual Locking Device HD-Lock-Modbus Ex-Proof

Ord. No.: 102100.1
Version: 1.5
Date: 1st June 2021
Dokument: 102100Err



1 General

The locking device HD-Lock Ex-Proof has been designed for use in doors, hatches, garage doors and rolling gates which are operated in explosive areas. Industrial applications with high requirements as well as applications in the maritime area can be covered with this product.

This device has been designed considering pressurized encapsulation according to directive 2014/34/EU. Standards EN 60079-0:2012+A11:2013 and EN 60079-1:2014 have been applied.

Note: The locking device must not be modified mechanically or opened. Repairs have to be carried out by the manufacturer.

If using the HD-Lock Ex in conjunction with the striking plate (counterpart), following function is achieved:

- Usage in explosive areas Ex II 2G Ex db IIB T4 Gb
- Electromechanical locking with feedback
- Active and passive feedback of the door condition "open" or "closed"
- High resilience
- Fast locking
- Emergency opening in the event of voltage breakdown

Through the use of robust materials (stainless steel) and a high-quality brushless motor, the locking device provides high reliability and durability.

1.1 Characteristics of the locking device

- Power Supply 12 V or 24 V
- Low noise
- Standby current is low
- Feedback of the bolt position
- Feedback of the door position
- Modbus Protocol
- Intelligent control integrated
- Several closing and opening attempts or Shutdown in case of blocking circumstances
- Stable design in a V4A (1.4404) stainless steel housing with high-quality surface
- V4A (1.4404) Stainless steel bolt with very high breaking force of 15kN when extended
- In case of voltage interruption, the bolt is in retracted position by mechanical spring
- High protection class and seawater resistance when mounted
- Short-circuit-proof outputs
- Temperature range from -15°C to 60°C

1.2 Scope of delivery

- Electromechanical locking device HD-Lock E with mirror polished front plate
- Housing pocket HD-Lock, black (POM 6000)
- Adjustable strike plate with 0.6mm tooth system (1.4404)
- Base plate with 0.6mm tooth system (1.4404)
- Coroplast Separation Base Plate
- 2 x Screws M5x20 DIN7991 (A4) corresponds to ISO 10642
- 2 x Screws M5x12 DIN912 (A4) corresponds to ISO 4762
- HD-Lock Manual

2 Installation

2.1 General installation

Important:

When installing the HD-Lock Ex, measures must be taken to prevent galvanic corrosion (recommendations: Tefgel, POM Pocket, coroplast insert). Repairs to the device and interventions inside of the device are only allowed by the manufacturer. Unauthorized repairs and interventions make it difficult to assess a warranty claim and may result in the loss of warranty.

The locking device must be installed in a suitable recess of the door frame and fastened by two M5x20 DIN7991 screws (Figure 2). The electrical connection is performed by using a wire outlet with a M12 connector. It should be noted that the bending radius of the wire must not be smaller than 30mm (fixed installation situation). The striking plate (counterpart) is installed in a recess of the door leaf (see Figure 3) and fastened with two M5x20 DIN7991 screws.

Important:

Care must be taken to ensure, that after installation of the locking device, the bolt is able to move freely into the striking plate (counterpart). If the free moving of the bolt is not guaranteed, this can lead to a malfunction of the locking device. It is forbidden to use a hammer during installation. Direct impact through a hammer can lead to a complete malfunction.



Figure 1 Hammer prohibition

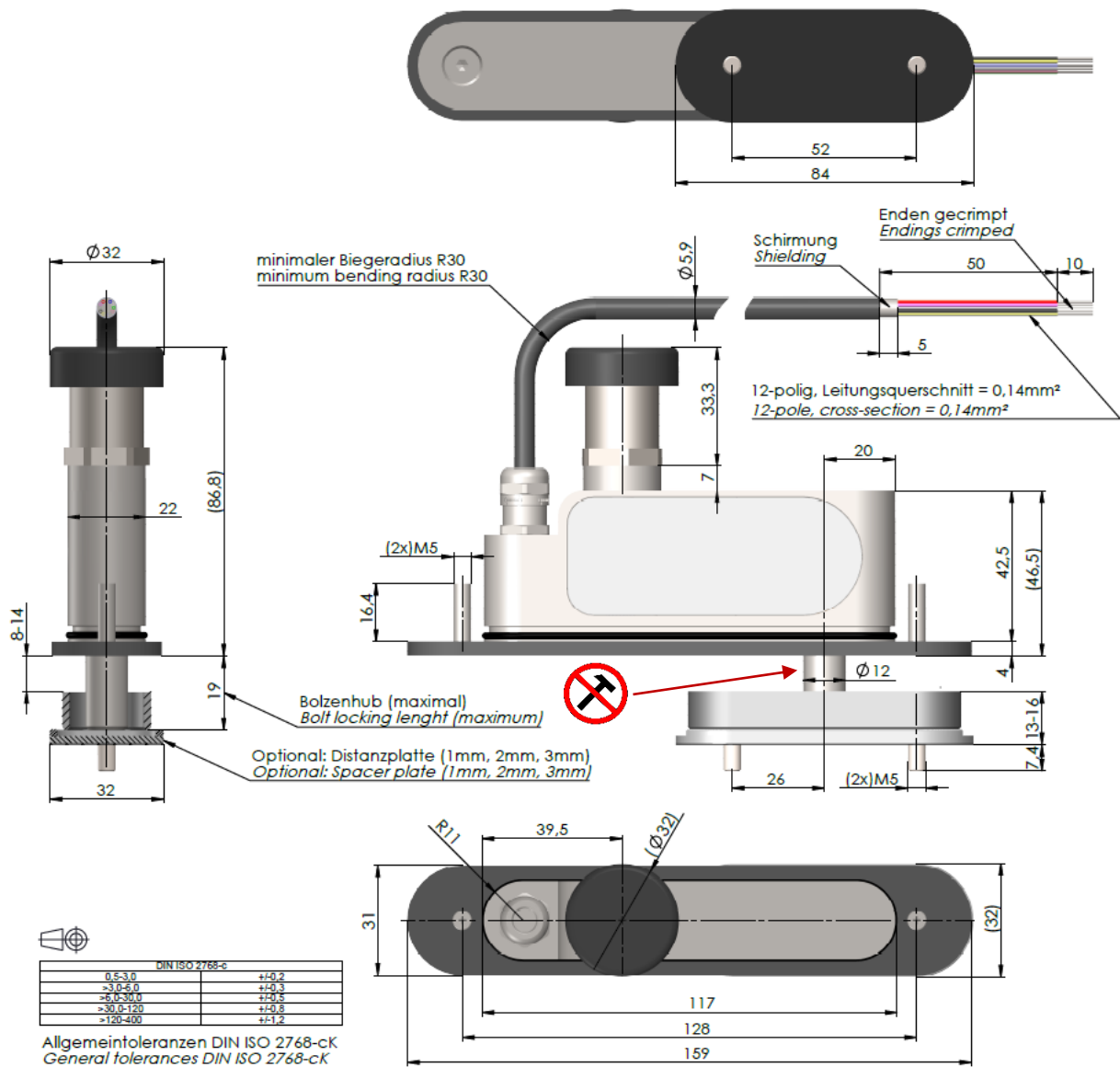

Figure 2 Product Drawing

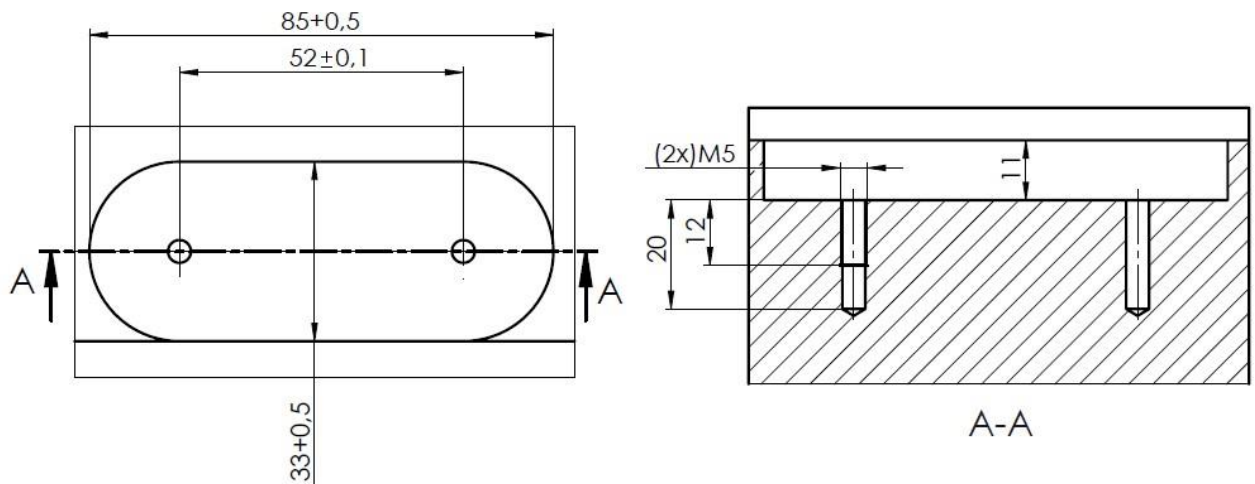

Figure 3 Recess for striking plate in door leaf

When installing the striking plate (counterpart), the insulating layer must be inserted first. The insulating layer prevents against galvanic corrosion. Then the base plate and the striking plate are installed. The striking plate structure is fastened with two M5 x 20 mm DIN 912 screws.

This structure is shown in Figure 4.

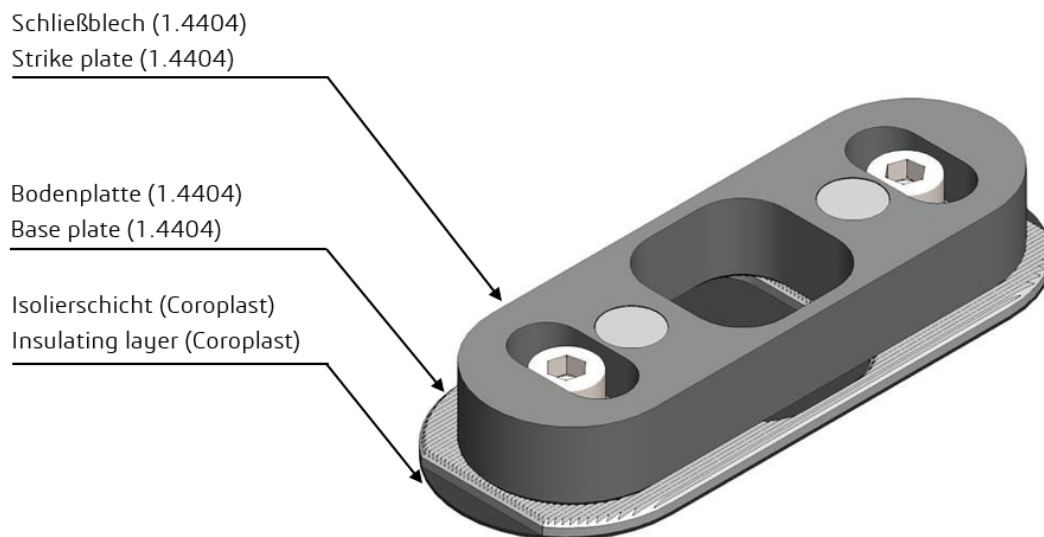

Figure 4 Structure of the striking plate

A proper and accurate installation of the striking plate in the door leaf is mandatory. In the event of incorrect installation of the striking plate, the function of the locking device is not guaranteed, and malfunctions may occur.

To ensure proper installation, the available adjustment kit (Type. 102935.0) from BSS should be used. The adjustment kit can be used to ensure the correct alignment of the striking plate.



Figure 5 Adjustment Kit Art. No. 102935.0

2.2 Door Stroke direction

In the delivery state, the automatic detection of the door stroke direction is active ("Direction" = "0"). The automatic detection of the door stroke direction only works after the HD Lock and the striking plate (counterpart) has been installed correctly, and after opening and closing the door once. The HD Lock must be supplied with voltage. The detection of the door stroke direction can be checked using a tool (e.g. Modbus-Poll) (Proximity Sign Register). If the detection does not meet the specifications of Figure 6, the automatic detection of the door stroke direction can be disabled.

To disable the automatic detection of the door stroke direction, a tool (e.g. Modbus poll) can be used to change the parameter "Direction" from "0" to "1" or "-1" for the correct door stroke direction. The correct setting can be seen in Figure 6, with a view to the mirror-polished surface of the locking device in the installed position.

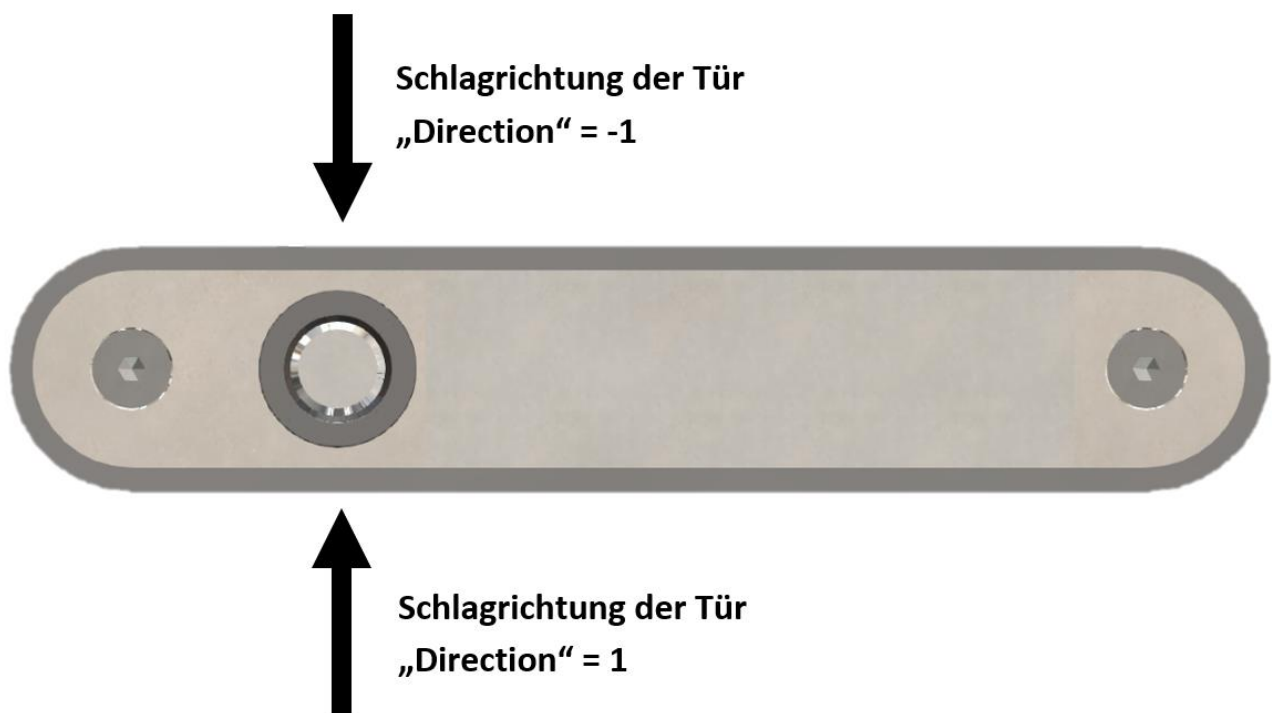

Figure 6 Setting the "Direction Function" depending on the stroke direction of the door

2.3 Switching Point (Door-Closed/Open_)

Software

The switching point of the door is set from factory. The door is detected if the door leaf with the installed striking plate is congruent to the locking device with a tolerance of $\pm 2-3$ mm.

Due to the alignment of the door leaf and door frame, a deviation of the congruence can occur. If the striking plate (counterpart) is detected by the locking device too early or not at all, the value "Proximity Threshold" must be corrected via the Modbus® interface (refer to Serial Interface Manual). Failure to do so, may result in incorrect door detection and locking malfunctions.

Potential-free output (Reed)*

The switching point of the potential-free output cannot be changed and can be more inaccurate compared to the software switching point. The potential-free output reacts when the striking plate (counterpart) is 5 mm to 15 mm away from the congruence (switching point area). The greater the installation distance between the HD-Lock and the striking plate (counterpart), the closer the switching point gets to the lower limit of the switching point area. From an installation distance of 12 mm, the striking plate (counterpart) cannot longer be reliably detected.

* Valid from serial number 200

3 Electrical interface

Electrical connection is performed by a 3 m long 12-core cable with a cable cross-section of 0.14 mm².

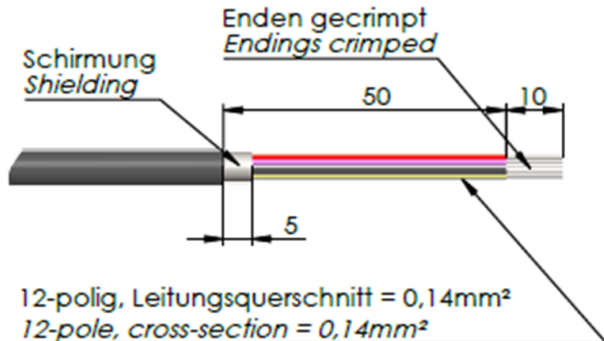

Figure 7 Connection lead

Inputs and Outputs of the locking device			
Signal	Wire color	Description	
BOLT-EXTENDED	Brown	Signal output for bolt status extended. (open collector output to VCC switching)	
GND	Blue	Ground power supply voltage	
DOOR- CLOSED/OPEN_	White	Signal output for door status. (open collector output to VCC switching)	
BOLT EXTEND/RETRACT	Green	Control input for the bolt. Internal pull down. If voltage > 10V bolt extends, If voltage < 4V bolt retracts	
RXTX-N	Pink	Modbus® Signal B (RS485) internally connected to RXTX-N-2	
NC	Yellow	Not connected	
RXTX-N-2	Black	Modbus® Signal B (RS485) internally connected to RXTX-N	
RXTX-P	Grey	Modbus® Signal A (RS485) internally connected to RXTX-P-2	
VCC	Red	Positive power supply voltage	
RXTX-P-2	Purple	Modbus® Signal A (RS485) internally connected to RXTX-P	
REED-1*	Grey/Pink	Potential-free output (normally open) Connects to REED-2 when the door is closed.	
REED-2*	Red/Blue	Potential-free output (normally open) Connects to REED-1 when the door is closed.	

* Valid from serial number 200

4 Commissioning

In the delivery state, after the operating voltage has been applied, the bolt is retracted. To extend the bolt, the door must be closed and the striking plate (counterpart) must be congruent to the locking device. If the door is closed and the "BoltExtend" signal is set active(> 10 V) the bolt will extend.

Functional test:

- Retract and extend the bolt of the locking device when the door is closed. Check the following points:
 - Closing or opening time approx. 1 second.
 - No grinding or stuttering of the bolt on the striking plate (counterpart). Free moving bolt.
 - Bolt extends properly approx. 19 mm
- If the operation is incorrect, please check the electrical interface and mechanics

If the bolt hits an obstacle during the locking procedure, the locking device retracts the bolt and repeats the locking procedure another 2 times. If the locking procedure is still not successful after these 2 attempts, the device will wait for 10 seconds before the locking procedure is repeated (this behavior can be changed by parameterization if necessary).

5 Troubleshooting

In case of malfunctions following points should be considered:

- **Wiring:**
 - Are all wires connected correctly?
 - Are pins bent in the plug?
- **Control signals:**
 - Is the power supply voltage 12 V or 24 V?
 - Is the required control signal correctly applied to the locking device?
- **Installation:**
 - Can the bolt move without obstacles and grinding?
 - Is the striking plate (counterpart) properly installed?
- **Operation:**
 - Is the switching point set correctly?
 - Does the door stroke direction of the door have to be set manually?

6 Modbus Protocol

The HD-Lock can be configured with the "Remote Terminal Unit Modbus" protocol (RTU Modbus). The following factory settings apply to this protocol. These can be changed retrospectively.

Important:

The maximum voltage for the serial interface is 3.3V. At higher voltage, there may be malfunction on the HD-Lock and/or the bus system.

Baud-Rate	19200 Bit/s
Parity	Even
Stoppbits	1
Bytesize	8
Slave ID	1

It is recommended to perform the parameterization by Modbus®. BSS offers a programming device (BSS Art.-No. 102900.3).

7 Technical data

Certifications	CE /  II 2G Ex db IIB T4 Gb
Power Supply / operation Voltage Range	24 V DC / 10... 30 V DC
Power input	min. 0,5 W / max. 4,6 W
Start-up current	max. 14 A / 24 V
Electrical fuse protection @ 24 V (tripping characteristic slow or inrush capacitance of >20,000 µF)	Each device must be fused with 0.5 A 5 A (<20 devices), 13 A (<50 devices), 25 A (<100 devices)
Standby power consumption (input is not active)	approx. 22 mA
Current supply required while locking and blockage	max. 190 mA / 24V
Holding current when bolt extended	Ca. 55 mA / 24V
Required input current supply to activate the input	0.2 mA
Minimum pulse duration at the inputs	20 msec
Resilience of the Open-Collector-Outputs*	30V, 250 mA (thermally protected)*
Resilience of the potential-free output (Reed)*	30V, 300 mA*
Bolt diameter	Ø 12 mm
Bolt locking length	19 mm
Closing /opening time without load	< 0,75 sec
Locking force	2 N
Retraction force without power supply	1.2 N
Operating temperature / storage temperature range	-15 C ... '60 C / -20 C ... '70 C
Protection Class	IP 65
Mechanical Dimensions	Figure 2 Product Drawing
Shear strength of the bolt	15 kN
Weight with connecting cables, with counterpart	950 g
Weight with connecting cables, without counterpart	800 g
Wire length	3 m
Material of housing	Stainless steel 1.4404
Material of bolt	Stainless steel 1.4404

* Valid from serial number 200. Devices with serial number < 200 has NO potential-free output and the resilience of the OC outputs is 25mA.

8 Figures

Figure 1 Hammer prohibition	4
Figure 2 Product Drawing	5
Figure 3 Recess for striking plate in door leaf	5
Figure 4 Structure of the striking plate	6
Figure 5 Adjustment Kit Art. No. 102935.0	6
Figure 6 Setting the "Direction Function" depending on the stroke direction of the door	7
Figure 7 Connection lead	9

